



topone

旭正機械股份有限公司
TOP-ONE MACHINERY CO.,LTD.

TM30

Multi-Tasking Turning Center 立式車銑複合機

- Equipped with an integrated spindle for turning and milling, combined with a swing head design.
- 4+1 axis machining capabilities.
- Multifunctional turning and milling for high-precision and complex workpiece machining.
- Multi-axis machining technology to enhance processing efficiency and workpiece quality.

配備內藏式車銑一體的主軸加上擺動頭設計
在單一機台上實現 4+1 軸複合加工能力
多功能切削與鑽銑，適合高精度與複雜工件加工
整合多軸加工技術，提升加工效率與工件品質

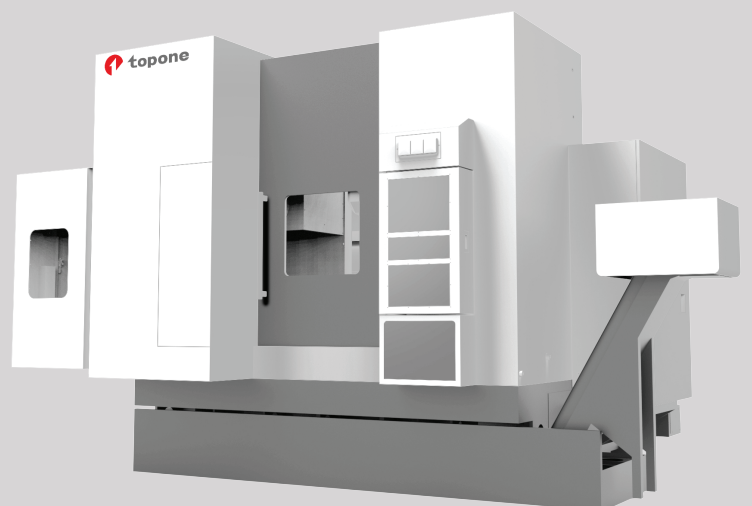

TM30 Specification/規格表

Item	項目		
Table C-Axis	工作台 C軸		
Chuck/Soft Jaw	夾頭/軟爪	inch	16"
Rotational Speed	轉速	rpm	600
Max. Load	最大載重	kg	200
Max. Worktable Load (C-Axis)	工作台最大荷重 (C軸)	kg	200
Max. Machining Diameter	最大加工直徑	mm	610
Min. Setting Angle	最小設定角度	deg.	0.001
Indexing Accuracy	分割精度	sec.	20
Repeatability	重複精度	sec.	4
Travel	行程		
X-Axis Travel	X軸行程	mm	762
Y-Axis Travel	Y軸行程	mm	400(±200)
Z-Axis Travel	Z軸行程	mm	460
Spindle	主軸		
Spindle Taper	主軸錐度		HSK-T63
Spindle Speed	主軸轉速	rpm	12,000
Central Coolant Supply	中央出水	bar	20
Spindle Lubrication	主軸潤滑		Grease Lubrication/油脂潤滑
Motor Power	馬達功率	Kw(S1/S6-40%)	16/20.8
Motor Torque	馬達扭力	Nm(S1/S6-40%)	47.8/62.1
B-Axis	B軸		
Rotation Speed	轉速	rpm	33.3
Indexing Accuracy	分割精度	sec.	20
Repeatability	重複精度	sec.	6
Tilting Angles	傾斜角度	deg.	±91
Tools	刀庫		
Magazine Type	刀庫種類		Disc type/圓盤式
Magazine capacity	刀庫容量	tools	24
Max. Tool Length	最大刀長	mm	250
Max. Tool Diameter (without adjacent tools)	刀具最大直徑 (無相鄰刀)	mm	Φ100
Max. Tool Weight	刀具最大重量	kg	8
Tool Exchange Time	換刀時間	sec.	3.27
Feed	軸向進給		
X-axis Rapid Feed	X軸 快速進給	m/min	12
Y-axis Rapid Feed	Y軸 快速進給	m/min	12
Z-axis Rapid Feed	Z軸 快速進給	m/min	12
Motor	馬達		
X-axis (AM11-50)	X軸 (AM11-50)	kW	2.3
Y-axis (AM8-40)	Y軸 (AM8-40)	kW	1.7
Z-axis (AM18-40)	Z軸 (AM18-40)	kW	3.9
Machine	機械		
Power Requirement	電源需求	KVA	100
Voltage	電壓		Three-phase 380V/三相
Min./Max. Air Pressure	氣壓需求 (最小/最大)	kg/cm ²	5~6
Airflow	空氣流量	NL	150
Floor Space Requirement	佔地面積	mm	3855x2630
Machine Height	機械高度	mm	2723
Machine Weight	機器重量	kg	12,000

Standard Accessories

- Syntec Control
- Fully Enclosed Sheet Metal
- Spindle Oil Cooler
- C-Axis Oil Cooler
- Portable Handwheel
- Toolbox and Operation Manual
- Signal Tower Light
- Automatic Lubrication System
- Spindle Air Blow
- Leveling Screws and Blocks
- Electrical Cabinet Heat Exchanger
- Chip Conveyor
- Hydraulic Unit

Optional Accessories

- B-Axis Linear Encoder
- X-Axis Linear Encoder
- Y-Axis Linear Encoder
- Z-Axis Linear Encoder
- CNC Cooling System
- Automatic Chuck
- Workpiece Measuring Device

標準配備

- 新代控制器
- 全密閉式鈹金
- 主軸油冷機
- C軸油冷機
- 移動式手輪
- 工具箱及操作手冊
- 警示燈
- 自動潤滑系統
- 主軸吹氣
- 水平調整螺絲及墊塊
- 電氣箱熱交換機
- 鏈板式鐵屑輸送機
- 油壓箱

選購配備

- B軸光學尺
- X軸光學尺
- Y軸光學尺
- Z軸光學尺
- 中心出水機
- 自動夾頭
- 工件量測器

Tool Magazine/刀庫換刀說明

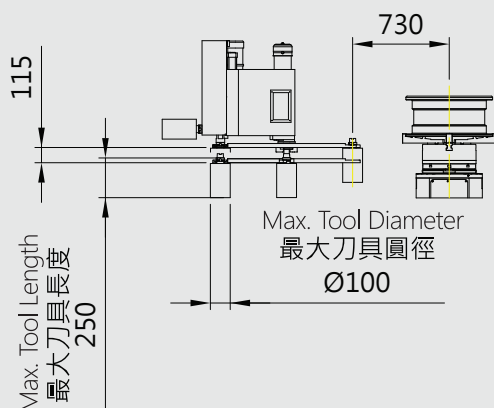

B-Axis Travel/B軸行程說明

